



# Optical Sensor Product Data Sheet LTR-559ALS-01

Spec No.: DS86-2013-0003

Effective Date: 07/09/2014

Revision: B

**LITE-ON DCC**

**RELEASE**

BNS-OD-FC001/A4

## Optical Sensor LTR-559ALS-01

### 1. Description

The LTR-559ALS-01 is an integrated low voltage I<sup>2</sup>C digital light sensor [ALS] and proximity sensor [PS] with built-in emitter, in a single miniature chip lead-free surface mount package. This sensor converts light intensity to a digital output signal capable of direct I<sup>2</sup>C interface. It provides a linear response over a wide dynamic range from 0.01 lux to 64k lux and is well suited to applications under high ambient brightness. With built-in proximity sensor (emitter and detector), LTR-559ALS-01 offers the feature to detect object at a user configurable distance.

The sensor supports an interrupt feature that removes the need to poll the sensor for a reading which improves system efficiency. The sensor also supports several features that help to minimize the occurrence of false triggering. This CMOS design and factory-set one time trimming capability ensure minimal sensor-to-sensor variations for ease of manufacturability to the end customers.

### 2. Features

- I<sup>2</sup>C interface (Fast Mode @ 400kbit/s)
- Ultra-small ChipLED package
- Built-in temperature compensation circuit
- Low active power consumption with standby mode
- Supply voltage range from 2.4V to 3.6V capable of 1.7V logic voltage
- Operating temperature range from -30°C to +70°C
- RoHS and Halogen free compliant
- Light Sensor
  - Close to human eye spectral response
  - Immunity to IR / UV Light Source
  - Automatically rejects 50 / 60 Hz lightings flicker
  - 6 dynamic range from 0.01 lux to 64k lux
  - 16-bit effective resolution
- Proximity Sensor
  - Built-in LED driver, emitter and detector
  - Programmable LED drive settings
  - 11-bit effective resolution
  - High ambient light suppression

## Optical Sensor LTR-559ALS-01

### 3. Applications

To control display backlight in

- Mobile Devices: Mobile phone, PDA
- Computing Devices: Notebook PC, Desktop Monitor
- Consumer Devices: LCD/PDP TV backlight systems, Cameras, Personal Navigation Device, Digital Photo Frame
- Dashboard

### 4. Ordering Information

Part Number	Packaging Type	Package	Quantity
LTR-559ALS-01	Tape and Reel	8-pin chipled package	8000

# Optical Sensor LTR-559ALS-01

## 5. Outline Dimensions

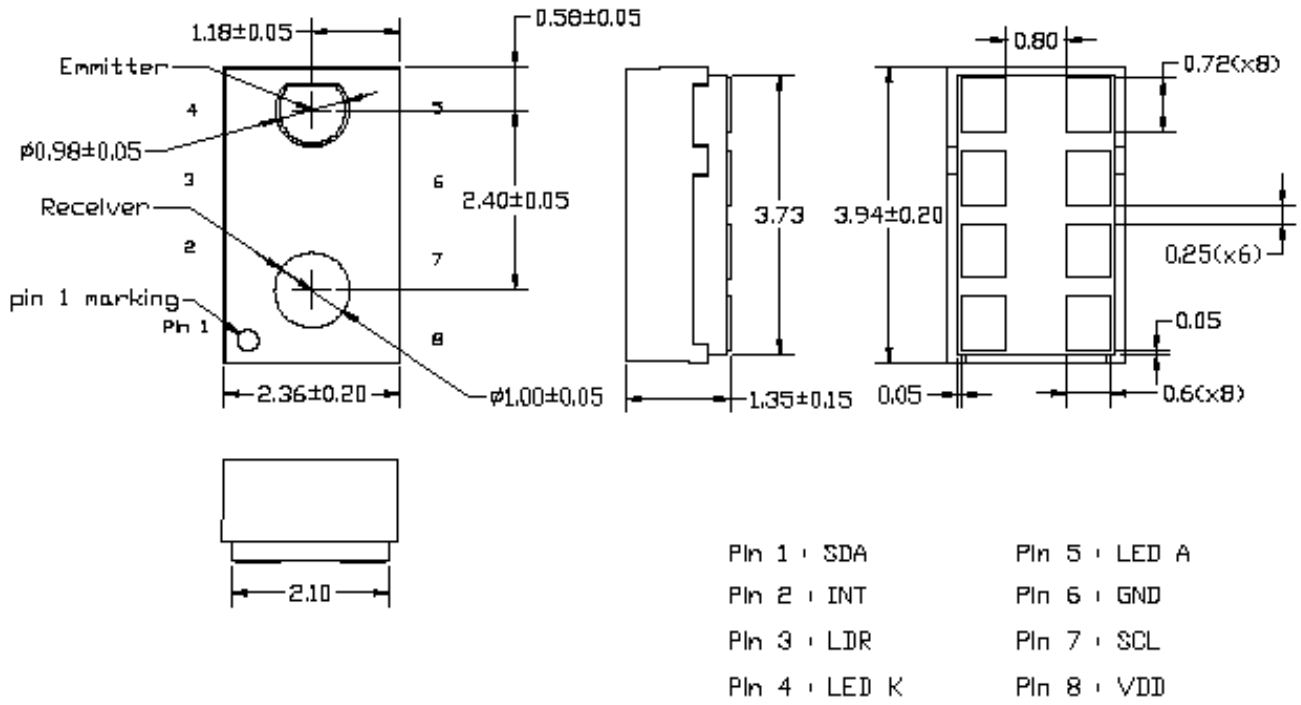

1. All dimensions are in millimeters

# Optical Sensor LTR-559ALS-01

## 6. Functional Block Diagram

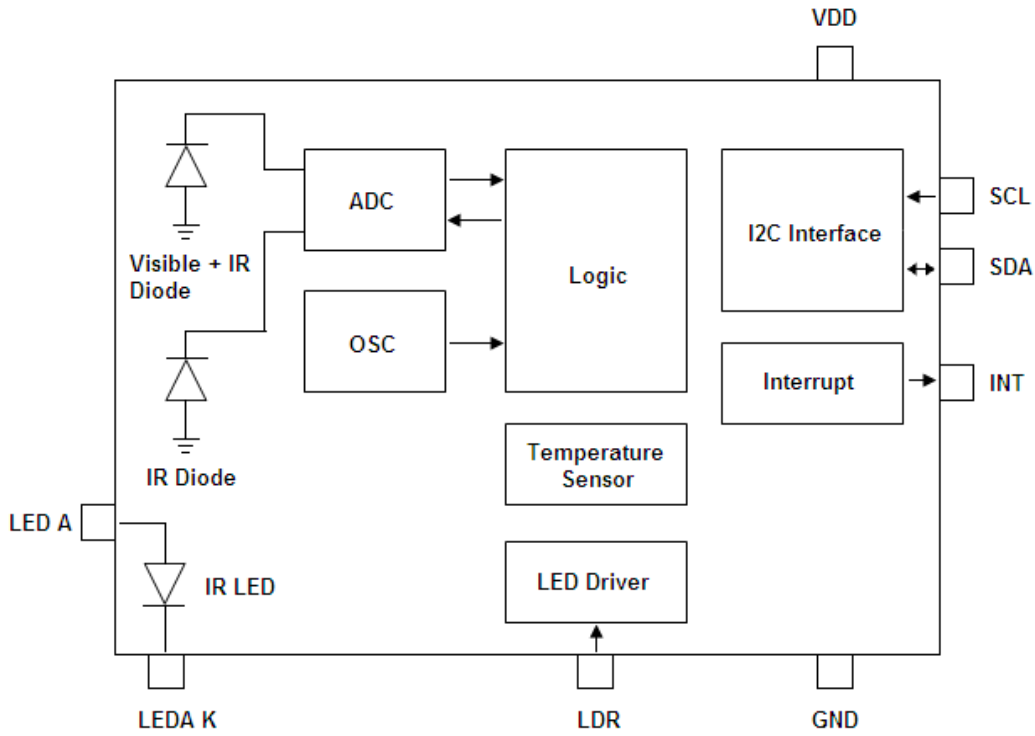

## 7. Application Circuit

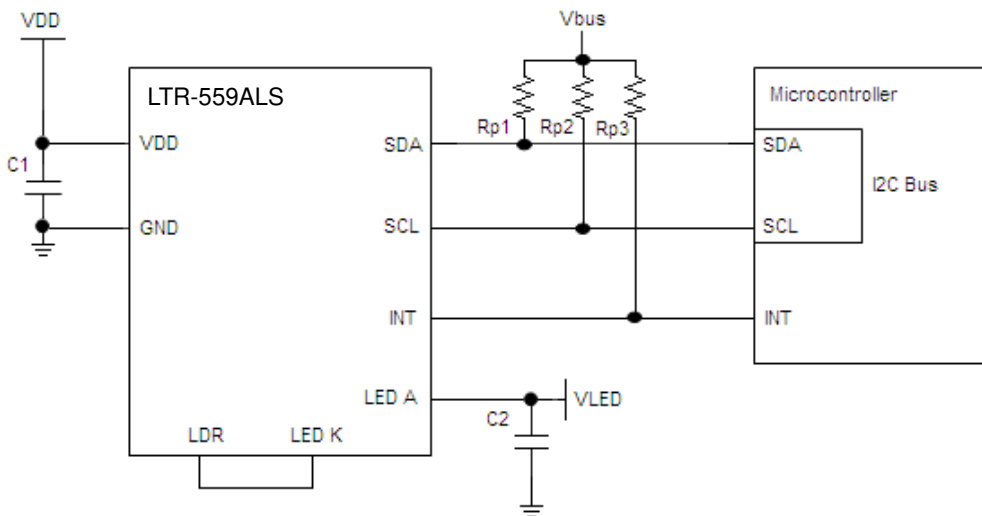

## Optical Sensor LTR-559ALS-01

I/O Pins Configuration Table

Pin	I/O Type	Symbol	Description
1	I/O	SDA	I <sup>2</sup> C serial data. This pin is an open drain input / output.
2	O	INT	Level Interrupt Pin. This pin is an open drain output.
3	I	LDR	LED Driver for proximity emitter. This pin is an open drain input.
4	O	LED K	LED Cathode. Connect to LDR pin if using internal LED driver circuit.
5	I	LED A	LED Anode. Connect to VDD or VBAT on PCB
6		GND	Ground
7	I	SCL	I <sup>2</sup> C serial clock. This pin is an open drain input.
8		VDD	Power Supply Voltage

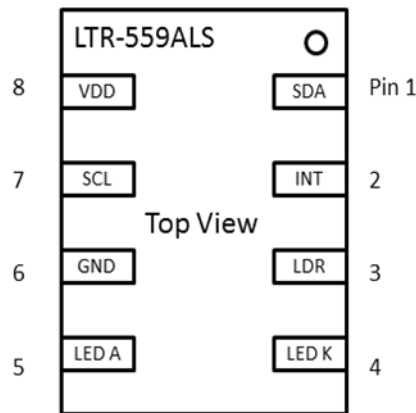

### Recommended Application Circuit Components

Component	Recommended Value
Rp1, Rp2, Rp3 [1]	1 kΩ to 10 kΩ
C1, C2	1uF ±20%, X7R Ceramic

[1] Selection of pull-up resistors value is dependent on bus capacitance values. For more details, please refer to I<sup>2</sup>C Specifications: [http://www.nxp.com/documents/user\\_manual/UM10204.pdf](http://www.nxp.com/documents/user_manual/UM10204.pdf)

## Optical Sensor LTR-559ALS-01

### 8. Ratings and Specifications

#### Absolute Maximum Ratings at Ta = 25°C

Parameter	Symbol	Rating	Unit
Supply Voltage	VDD	3.8	V
Digital Voltage Range	SCL, SDA, INT	-0.5 to 3.8	V
Digital Output Current	SCL, SDA, INT	-1 to 20	mA
Storage Temperature	T <sub>stg</sub>	-40 to 100	°C

Note: Exceeding these ratings could cause damage to the sensor. All voltages are with respect to ground. Currents are positive into, negative out of the specified terminal.

#### Recommended Operating Conditions

Description	Symbol	Min.	Typ.	Max.	Unit
Supply Voltage	VDD	2.4		3.6	V
LED Supply Voltage	VLED	2.5		4.35	V
Interface Bus Power Supply Voltage	V <sub>IO</sub>	1.7		3.6	V
Operating Temperature	T <sub>ope</sub>	-30		70	°C

#### Electrical & Optical Specifications

All specifications are at VDD = 3.0V, T<sub>ope</sub> = 25°C, unless otherwise noted.

Parameter	Min.	Typ.	Max.	Unit	Condition
Active Supply Current			250	uA	Active Mode, T <sub>ope</sub> = 25°C
Standby Current			5	uA	Standby / Sleep Mode
Initial Startup Time	60	100	1000	ms	(Note 1)
Wakeup Time from Standby			10	ms	(Note 1)

## Optical Sensor LTR-559ALS-01

### Light Sensor

Parameter	Min.	Typ.	Max.	Unit	Condition
Full Scale ADC Count			65535	count	
Dark ADC Count	0		6	count	Ch0, Lux = 0
	0		6	count	Ch1, Lux = 0
ADC Count (Gain=96)	3200	4900	6600	count	Ch0 White LED 200 Lux Integration Time : 50ms Measurement Time : 100ms
	1200	1800	2400	count	Ch1 White LED 200 Lux Integration Time : 50ms Measurement Time : 100ms
ALS Ratio	0.15	0.26	0.35		Ratio = Ch1/(Ch1 + Ch0) Lux = 200 (White LED)

### Proximity Sensor

Parameter	Min.	Typ.	Max.	Unit	Condition
Full Scale ADC Count			2047	count	
Peak Sensitivity	840	855	870	nm	
Detection Distance	20			nm	100mA, 4 pulses, 18% Gray card
Ambient Light Suppression			50k	Lux	Direct sunlight
LED Pulse Count	1		15	Pulses	
LED Pulse Frequency	30k		100k	Hz	Increment of 10k Hz
LED Duty Cycle	25		100	%	Increment of 25%
		5		mA	LED Peak Current = 000
		10		mA	LED Peak Current = 001
		20		mA	LED Peak Current = 010
		50		mA	LED Peak Current = 011
		100		mA	LED Peak Current = 1XX
Optical Rise / Fall Time	100			ns	

# Optical Sensor LTR-559ALS-01

## Note 1: Startup Sequence

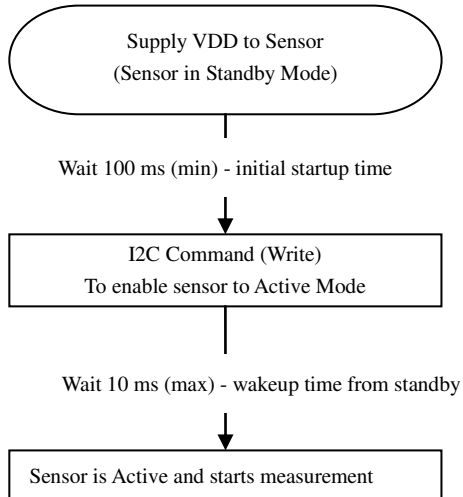

## LUX Formula

Refer to Appendix A for the lux formula

## Optical Sensor LTR-559ALS-01

### AC Electrical Characteristics

All specifications are at VBus = 1.8V, T<sub>ope</sub> = 25°C, unless otherwise noted.

Parameter	Symbol	Min.	Max.	Unit
SCL clock frequency	$f_{SCL}$	1	400	kHz
Bus free time between a STOP and START condition	$t_{BUF}$	1.3		us
Hold time (repeated) START condition. After this period, the first clock pulse is generated	$t_{HD;STA}$	0.6		us
LOW period of the SCL clock	$t_{LOW}$	1.3		us
HIGH period of the SCL clock	$t_{HIGH}$	0.6		us
Set-up time for a repeated START condition	$t_{SU;STA}$	0.6		us
Set-up time for STOP condition	$t_{SU;STO}$	0.6		us
Rise time of both SDA and SCL signals	$t_r$	30	300	ns
Fall time of both SDA and SCL signals	$t_f$	30	300	ns
Data hold time	$t_{HD;DAT}$	0.3	0.9	us
Data setup time	$t_{SU;DAT}$	100		ns
Pulse width of spikes which must be suppressed by the input filter	$t_{SP}$	0	50	ns

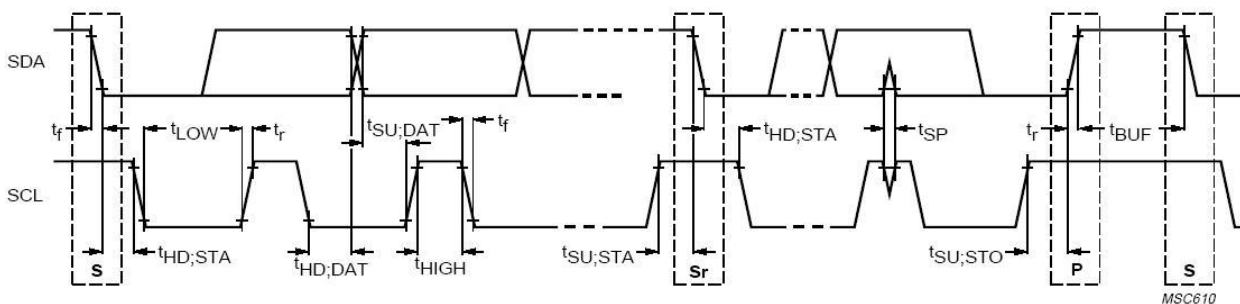

**Definition of timing for I<sup>2</sup>C bus**

## 9. Principles of Operation

### I<sup>2</sup>C Protocols

· I<sup>2</sup>C Write Protocol (type 1):

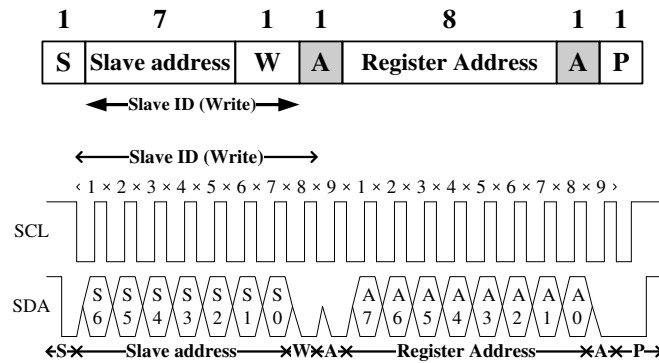

· I<sup>2</sup>C Write Protocol (type 2):

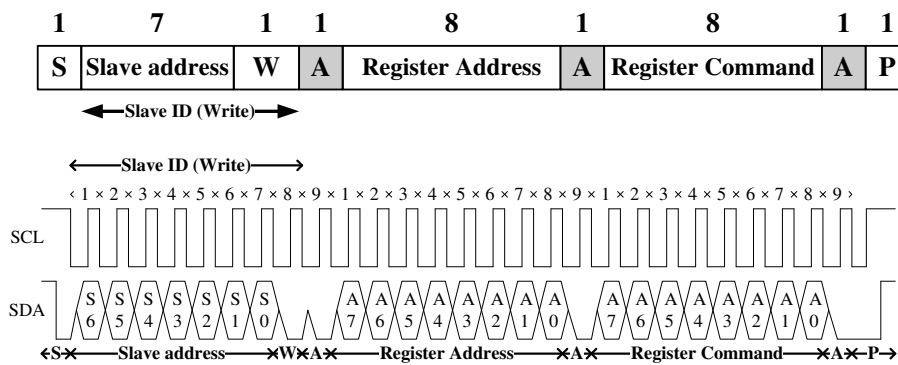

· I<sup>2</sup>C Read Protocol:

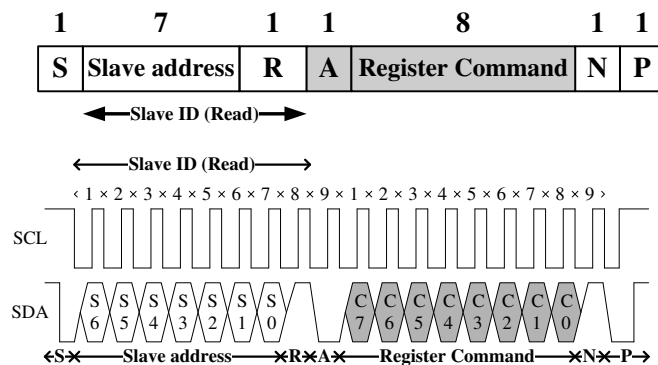

# Optical Sensor LTR-559ALS-01

· I<sup>2</sup>C Read (Combined format) Protocol:

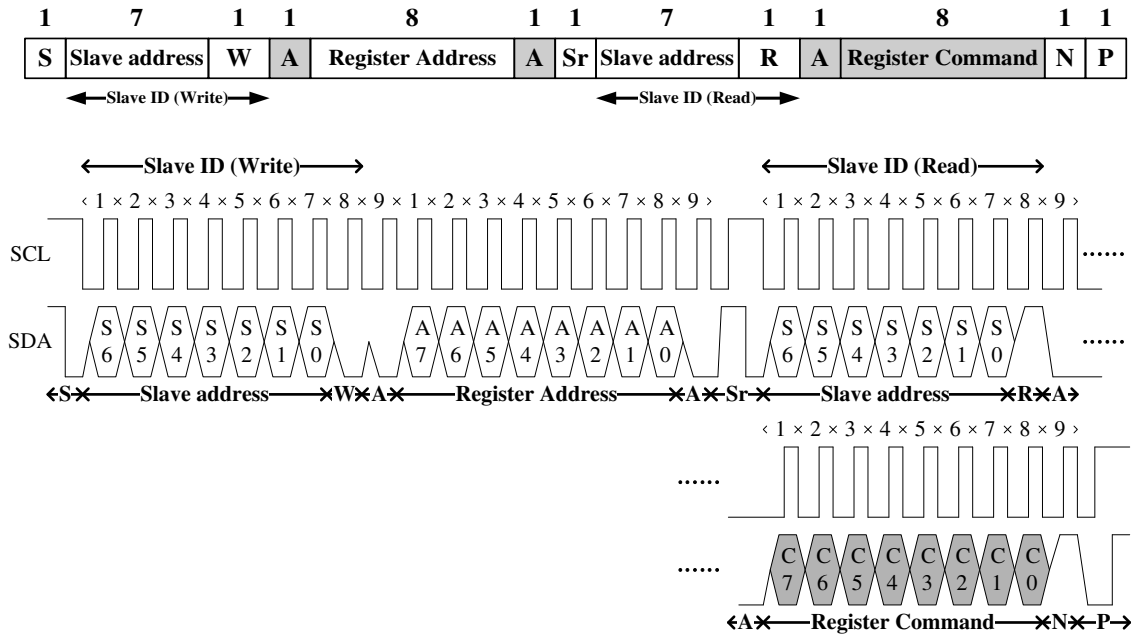

- A** Acknowledge (0 for an ACK)
- S** Start condition
- P** Stop condition
- W** Write (0 for writing)
- Slave-to-master**
- N** Non-Acknowledge (1 for an NACK)
- Sr** Repeated Start condition
- R** Read (1 for read)
- Master-to-Slave**

## I<sup>2</sup>C Slave Address

The 7 bits slave address for this sensor is 0x23H. A read/write bit should be appended to the slave address by the master device to properly communicate with the sensor.

I <sup>2</sup> C Slave Address									
Command Type	(0x29H)							W/R	value
	Bit7	Bit6	Bit5	Bit4	Bit3	Bit2	Bit1	Bit0	
Write	0	1	0	0	0	1	1	0	0x46H
Read	0	1	0	0	0	1	1	1	0x47H

## Optical Sensor LTR-559ALS-01

### Register Set

Addr	R / W	Register Name	Description	Reset Value
0x80	R/W	ALS_CONTR	ALS operation mode control SW reset	0x00
0x81	R/W	PS_CONTR	PS operation mode control	0x00
0x82	R/W	PS_LED	PS LED setting	0x7F
0x83	R/W	PS_N_PULSES	PS number of pulses	0x01
0x84	R/W	PS_MEAS_RATE	PS measurement rate in active mode	0x02
0x85	R/W	ALS_MEAS_RATE	ALS measurement rate in active mode	0x03
0x86	R	PART_ID	Part Number ID and Revision ID	0x92
0x87	R	MANUFAC_ID	Manufacturer ID	0x05
0x88	R	ALS_DATA_CH1_0	ALS measurement CH1 data, lower byte	0x00
0x89	R	ALS_DATA_CH1_1	ALS measurement CH1 data, upper byte	0x00
0x8A	R	ALS_DATA_CH0_0	ALS measurement CH0 data, lower byte	0x00
0x8B	R	ALS_DATA_CH0_1	ALS measurement CH0 data, upper byte	0x00
0x8C	R	ALS_PS_STATUS	ALS and PS new data status	0x00
0x8D	R	PS_DATA_0	PS measurement data, lower byte	0x00
0x8E	R	PS_DATA_1	PS measurement data, upper byte	0x00
0x8F	R/W	INTERRUPT	Interrupt settings	0x00
0x90	R/W	PS_THRES_UP_0	PS interrupt upper threshold, lower byte	0xFF
0x91	R/W	PS_THRES_UP_1	PS interrupt upper threshold, upper byte	0x07
0x92	R/W	PS_THRES_LOW_0	PS interrupt lower threshold, lower byte	0x00
0x93	R/W	PS_THRES_LOW_1	PS interrupt lower threshold, upper byte	0x00
0x94	R/W	PS_OFFSET_1	PS offset, upper byte	0x00
0x95	R/W	PS_OFFSET_0	PS offset, lower byte	0x00
0x97	R/W	ALS_THRES_UP_0	ALS interrupt upper threshold, lower byte	0xFF
0x98	R/W	ALS_THRES_UP_1	ALS interrupt upper threshold, upper byte	0xFF
0x99	R/W	ALS_THRES_LOW_0	ALS interrupt lower threshold, lower byte	0x00
0x9A	R/W	ALS_THRES_LOW_1	ALS interrupt lower threshold, upper byte	0x00
0x9E	R/W	INTERRUPT_PERSIST	ALS / PS Interrupt persist setting	0x00

#### Notes:

- 1) When reading ALS data registers, read sequence should always be from lower address to higher address (E.g. For ALS data, Ch1 data should be read first followed by Ch0 data. Read sequence should be 0x88, 0x89, 0x8A, 0x8B. When 0x8B is read, all four ALS data registers will be populated with new set of data).
- 2) When setting of INTERRUPT register (addr 0x8F) is necessary, it should be done before the device is in Active mode.

## Optical Sensor LTR-559ALS-01

### ALS\_CONTR Register (0x80)

The ALS\_CONTR register controls the ALS Gain setting, ALS operation modes and software (SW) reset for the sensor. The ALS sensor can be set to either standby mode or active mode. At either of these modes, the I<sup>2</sup>C circuitry is always active. The default mode after power up is standby mode. During standby mode, there is no ALS measurement performed but I<sup>2</sup>C communication is allowed to enable read/write to all the registers.

0x80	ALS_CONTR (default = 0x00)							
	B7	B6	B5	B4	B3	B2	B1	B0
	Reserved			ALS Gain			SW Reset	ALS Mode

Field	Bits	Default	Type	Description	
Reserved	7:5	000	--	--	MUST write to 000 (default)
ALS Gain	4:2	000	RW	000	Gain 1X → 1 lux to 64k lux (default)
				001	Gain 2X → 0.5 lux to 32k lux
				010	Gain 4X → 0.25 lux to 16k lux
				011	Gain 8X → 0.125 lux to 8k lux
				100	Reserved
				101	Reserved
				110	Gain 48X → 0.02 lux to 1.3k lux
				111	Gain 96X → 0.01 lux to 600 lux
SW reset	1	0	RW	0	Initial start-up procedure is NOT started (default)
				1	Initial start-up procedure is started, bit has default value of 0 after start-up
ALS mode	0	0	RW	0	Stand-by mode (default)
				1	Active mode

## Optical Sensor LTR-559ALS-01

### PS\_CONTR Register (0x81)

The PS\_CONTR register controls the PS operation modes. The PS sensor can be set to either standby mode or active mode. At either of these modes, the I<sup>2</sup>C circuitry is always active. The default mode after power up is standby mode. During standby mode, there is no PS measurement performed but I<sup>2</sup>C communication is allowed to enable read/write to all the registers.

PS Saturation Indicator Enable bit is used for enabling the saturation indicator in Bit 7 of PS\_DATA register (0x8E).

0x81	PS_CONTR (default = 0x00)							
	B7	B6	B5	B4	B3	B2	B1	B0
	<i>Reserved</i>		<i>PS Saturation Indicator Enable</i>	<i>Reserved</i>			<i>PS Mode</i>	

Field	Bits	Default	Type	Description	
Reserved	7:6	00	--	--	MUST write to 00
PS Saturation Indicator Enable	5	0	RW	0	Saturation indicator disable
				1	Saturation indicator enable
Reserved	4:2	000	--	--	Must be 0
PS Mode	1:0	00	RW	00	Stand-by mode (default)
				01	
				10	Active mode
				11	

## Optical Sensor LTR-559ALS-01

### PS\_LED Register (0x82)

The PS\_LED register controls the LED pulse modulation frequency, LED current duty cycle and LED peak current.

0x82	PS_LED (default = 0x7F)							
	B7	B6	B5	B4	B3	B2	B1	B0
	<i>LED Pulse Frequency</i>			<i>LED Duty Cycle</i>		<i>LED Peak Current</i>		

Field	Bits	Default	Type	Description	
LED Pulse Modulation Frequency	7:5	011	RW	000	LED pulse period = 30kHz
				001	LED pulse period = 40kHz
				010	LED pulse period = 50kHz
				011	LED pulse period = 60kHz (default)
				100	LED pulse period = 70kHz
				101	LED pulse period = 80kHz
				110	LED pulse period = 90kHz
				111	LED pulse period = 100kHz
LED Duty Cycle	4:3	11	RW	00	DUTY = 25%
				01	DUTY = 50%
				10	DUTY = 75%
				11	DUTY = 100% (default)
LED Current	2:0	111	RW	000	LED pulsed current level = 5mA
				001	LED pulsed current level = 10mA
				010	LED pulsed current level = 20mA
				011	LED pulsed current level = 50mA
				100	LED pulsed current level = 100mA (default)
				101	
				110	
				111	

# Optical Sensor LTR-559ALS-01

## PS\_N\_Pulses Register (0x83)

The PS\_N\_Pulses register controls the number of LED pulses to be emitted.

0x83	PS_N_Pulses (default = 0x01)							
	B7	B6	B5	B4	B3	B2	B1	B0
	<i>Reserved</i>				<i>LED Pulse Count</i>			

Field	Bits	Default	Type	Description	
Reserved	7:4	0000	--	--	0000 (default)
PS number of LED pulses	3:0	0001	RW	0000	RESERVED
				0001	Number of pulses = 1 (default)
				0010	Number of pulses = 2
				0011	Number of pulses = 3
				0100	Number of pulses = 4
				0101	Number of pulses = 5
				0110	Number of pulses = 6
				0111	Number of pulses = 7
				1000	Number of pulses = 8
				1001	Number of pulses = 9
				1010	Number of pulses = 10
				1011	Number of pulses = 11
				1100	Number of pulses = 12
				1101	Number of pulses = 13
				1110	Number of pulses = 14
1111	Number of pulses = 15				

## Optical Sensor LTR-559ALS-01

### PS\_MEAS\_RATE Register (0x84)

The PS\_MEAS\_RATE register controls the timing of the periodic measurements of the PS in active mode. PS Measurement Repeat Rate is the interval between PS\_DATA registers update.

0x84	PS_MEAS_RATE (default = 0x02)							
	B7	B6	B5	B4	B3	B2	B1	B0
	<i>Reserved</i>				<i>PS Measurement Repeat Rate</i>			

Field	Bits	Default	Type	Description	
Reserved	7:4	0000	--	--	0000 (default)
PS measurement rate	3:0	0010	RW	0000	50ms
				0001	70ms
				0010	100ms (default)
				0011	200ms
				0100	500ms
				0101	1000ms
				0110	2000ms
				0111	
				1XXX	10ms

## Optical Sensor LTR-559ALS-01

### ALS\_MEAS\_RATE Register (0x85)

The ALS\_MEAS\_RATE register controls the integration time and timing of the periodic measurement of the ALS in active mode. ALS Measurement Repeat Rate is the interval between ALS\_DATA registers update. ALS Integration Time is the measurement time for each ALS cycle.

ALS Measurement Repeat Rate must be set to be equal or larger than the ALS Integration Time. If ALS Measurement Repeat Rate is set to be smaller than ALS Integration Time, it will automatically be reset to be equal to ALS Integration Time by the IC internally.

0x85	ALS_MEAS_RATE (default = 0x03)							
	B7	B6	B5	B4	B3	B2	B1	B0
	<i>Reserved</i>		<i>ALS Integration Time</i>			<i>ALS Measurement Repeat Rate</i>		

Field	Bits	Default	Type	Description	
Reserved	7:6	00	--	--	--
ALS integration time	5:3	000	RW	000	100ms (default)
				001	50ms
				010	200ms
				011	400ms
				100	150ms
				101	250ms
				110	300ms
ALS measurement rate	2:0	011	RW	000	50ms
				001	100ms
				010	200ms
				011	500ms (default)
				100	1000ms
				101	2000ms
				110	
				111	

## Optical Sensor LTR-559ALS-01

### PART\_ID Register (0x86) (Read Only)

The PART\_ID register defines the part number and revision identification of the sensor.

0x86	PART_ID (default = 0x92)							
	B7	B6	B5	B4	B3	B2	B1	B0
	<i>Part Number ID</i>				<i>Revision ID</i>			

Field	Bits	Default	Type	Description
Part Number ID	7:4	1001	R	Part ID 0x09H
Revision ID	3:0	0010	R	Revision ID 0x02H

### MANUFAC\_ID Register (0x87) (Read Only)

The MANUFAC\_ID register defines the manufacturer identification of the sensor.

0x87	MANUFAC_ID (default = 0x05)							
	B7	B6	B5	B4	B3	B2	B1	B0
	<i>Manufacturer ID</i>							

Field	Bits	Default	Type	Description
Manufacturer ID	7:0	00000101	R	Manufacturer ID (0x05H)

## Optical Sensor LTR-559ALS-01

### ALS\_DATA\_CH1 Register (0x88 / 0x89) (Read Only)

The ALS\_DATA registers should be read as a group, with the lower address read back first (i.e. read 0x88 first, then read 0x89). These two registers should also be read before reading channel-0 data (from registers 0x8A, 0x8B).

When the I<sup>2</sup>C read operation starts, all four ALS data registers are locked until the I<sup>2</sup>C read operation of register 0x8B is completed. This will ensure that the data in the registers is from the same measurement even if an additional integration cycle ends during the read operation. New measurement data is stored into temporary registers and the ALS\_DATA registers are updated as soon as there is no on-going I<sup>2</sup>C read operation.

The ALS ADC channel-1 data is expressed as a 16-bit data spread over two registers. The ALS\_DATA\_CH1\_0 and ALS\_DATA\_CH1\_1 registers provide the lower and upper byte respectively.

0x88	ALS_DATA_CH1_0 (default = 0x00)							
	B7	B6	B5	B4	B3	B2	B1	B0
	<i>ALS Data Ch1 Low</i>							

0x89	ALS_DATA_CH1_1 (default = 0x00)							
	B7	B6	B5	B4	B3	B2	B1	B0
	<i>ALS Data Ch1 High</i>							

Field	Address	Bits	Default	Type	Description
ALS Data Ch1 Low	0x88	7:0	00000000	R	ALS ADC channel 1 lower byte data
ALS Data Ch1 High	0x89	7:0	00000000	R	ALS ADC channel 1 upper byte data

## Optical Sensor LTR-559ALS-01

### ALS\_DATA\_CH0 Register (0x8A / 0x8B) (Read Only)

These two registers should be read after reading channel-1 data (from registers 0x88, 0x89). Lower address register should be read first (i.e. read 0x8A first, then read 0x8B). See ALS\_DATA\_CH1 register information above. The ALS ADC channel-0 data is expressed as a 16-bit data spread over two registers. The ALS\_DATA\_CH0\_0 and ALS\_DATA\_CH0\_1 registers provide the lower and upper byte respectively.

0x8A	ALS_DATA_CH0_0 (default = 0x00)							
	B7	B6	B5	B4	B3	B2	B1	B0
	<i>ALS Data Ch0 Low</i>							

0x8B	ALS_DATA_CH0_1 (default = 0x00)							
	B7	B6	B5	B4	B3	B2	B1	B0
	<i>ALS Data Ch0 High</i>							

Field	Address	Bits	Default	Type	Description
ALS Data Ch0 Low	0x8A	7:0	00000000	R	ALS ADC channel 0 lower byte data
ALS Data Ch0 High	0x8B	7:0	00000000	R	ALS ADC channel 0 upper byte data

## Optical Sensor LTR-559ALS-01

### ALS\_PS\_STATUS Register (0x8C) (Read Only)

The ALS\_PS\_STATUS register stores the information about ALS data status. New data means data has not been read yet. When the measurement is completed and data is written to the data register, the data status bit will be set to logic 1. When the data register is read, the data status bit will be set to logic 0.

Interrupt status determines if the ALS interrupt criteria are met. It will check if the ALS measurement data is outside of the range defined by the upper and lower threshold limits.

ALS Data Valid bit indicates the validity of the ALS data in Ch0 and Ch1.

0x8C	ALS_PS_STATUS (default = 0x00)							
	B7	B6	B5	B4	B3	B2	B1	B0
	<i>ALS Data Valid</i>	<i>ALS Gain</i>			<i>ALS Interrupt Status</i>	<i>ALS Data Status</i>	<i>PS Interrupt Status</i>	<i>PS Data Status</i>

Field	Bits	Default	Type	Description	
ALS Data Valid	7	0	R	0	ALS Data is Valid (default)
				1	ALS Data is Invalid
ALS Data Gain Range	6:4	000	R	000	ALS measured data in Gain 1X (default)
				001	ALS measured data in Gain 2X
				010	ALS measured data in Gain 4X
				011	ALS measured data in Gain 8X
				100	Invalid
				101	Invalid
				110	ALS measured data in Gain 48X
				111	ALS measured data in Gain 96X
ALS interrupt status	3	0	R	0	Interrupt signal INACTIVE (default)
					Interrupt signal ACTIVE
ALS data status	2	0	R	0	OLD data (data already read), (default)
				1	NEW data (first time data is being read)
PS Interrupt Status	1	0	R	0	Interrupt signal INACTIVE (default)
				1	Interrupt signal ACTIVE
PS Data Status	0	0	R	0	OLD data (data already read), (default)
				1	NEW data (first time data is being read)

## Optical Sensor LTR-559ALS-01

### PS\_DATA\_0 Register (0x8D / 0x8E) (Read Only)

The PS ADC channel data are expressed as a 11-bit data spread over two registers. The PS\_DATA\_0 and PS\_DATA\_1 registers provide the lower and upper byte respectively. When the I<sup>2</sup>C read operation starts, both the registers are locked until the I<sup>2</sup>C read operation is completed. This will ensure that the data in the registers is from the same measurement even if an additional integration cycle ends during the read operation. New measurement data is stored into temporary registers and the PS\_DATA registers are updated as soon as there is no on-going I<sup>2</sup>C read operation.

PS Saturation Flag is used for monitoring the internal IC saturation. It will be flagged when the IC has reached saturation and not able to perform any further PS measurement. The PS Saturation Indicator Enable bit in PS\_CONTR Register (0x81) has to be enabled in order to use this feature. If it is not enable, the flag will always be indicated as 0.

0x8D	PS_DATA_0 (default = 0x00)							
	B7	B6	B5	B4	B3	B2	B1	B0
	<i>PS Data Low</i>							

0x8E	PS_DATA_1 (default = 0x00)							
	B7	B6	B5	B4	B3	B2	B1	B0
	<i>PS Saturation Flag</i>	<i>Reserved</i>				<i>PS Data High</i>		

Field	Address	Bits	Default	Type	Description	
PS Data, Low	0x8D	7:0	00000000	R	--	PS ADC lower byte data
PS Saturation Flag	0x8E	7	0	R	0	PS not saturated
					1	PS saturated
Reserved	0x8E	6:3	00000	--	--	--
PS Data, High	0x8E	2:0	000	R	--	PS ADC upper byte data

## Optical Sensor LTR-559ALS-01

### INTERRUPT Register (0x8F) (Read Only)

The INTERRUPT register controls the operation of the interrupt pin and functions. When the Interrupt Mode is set to 00, the INT output pin 2 is inactive / disabled and will not trigger any interrupt. However at this condition, the ALS\_PS\_STATUS register will still be updated.

Note that when this register is to be set with values other than its default values, it should be set before device is in Active mode.

0x8F	INTERRUPT (default = 0x00)							
	B7	B6	B5	B4	B3	B2	B1	B0
	<i>Reserved</i>					<i>Interrupt Polarity</i>	<i>Interrupt Mode</i>	

Field	Bits	Default	Type	Description	
RESERVED	7:3	00000	--	--	Must write as 00000
Interrupt Polarity	2	0	RW	0	INT pin is considered active when it is a logic 0 (default)
				1	INT pin is considered active when it is a logic 1
Interrupt Mode	1:0	0	RW	00	Interrupt pin is INACTIVE / high impedance state (default)
				01	Only PS measurement can trigger interrupt
				10	Only ALS measurement can trigger interrupt
				11	Both ALS and PS measurement can trigger interrupt

## Optical Sensor LTR-559ALS-01

### PS\_THRES Register (0x90 / 0x91 / 0x92 / 0x93)

The PS\_THRES\_UP and PS\_THRES\_LOW registers determines the upper and lower limit of the interrupt threshold value respectively. These two values form a range and the interrupt function compares if the measurement value in PS\_DATA registers is inside or outside the range. The interrupt function is active if the measurement data is outside the range defined by the upper and lower limits. The data format for PS\_THRES must be the same as PS\_DATA registers. These registers must be applied dynamically to have hysteresis interruption.

0x90	PS_THRES_UP_0 (default = 0xFF)							
	B7	B6	B5	B4	B3	B2	B1	B0
	<i>PS Upper Threshold Low</i>							

0x91	PS_THRES_UP_1 (default = 0x07)							
	B7	B6	B5	B4	B3	B2	B1	B0
	<i>Reserved</i>				<i>PS Upper Threshold High</i>			

0x92	PS_THRES_LOW_0 (default = 0x00)							
	B7	B6	B5	B4	B3	B2	B1	B0
	<i>PS Lower Threshold Low</i>							

0x93	PS_THRES_LOW_1 (default = 0x00)							
	B7	B6	B5	B4	B3	B2	B1	B0
	<i>Reserved</i>				<i>PS Lower Threshold High</i>			

## Optical Sensor LTR-559ALS-01

Field	Address	Bits	Default	Type	Description
PS Upper Threshold Low	0x90	7:0	11111111	RW	PS upper threshold lower byte data
Reserved	0x91	7:3	00000	--	Reserved
PS Upper Threshold High	0x91	2:0	111	RW	PS upper threshold upper byte data
PS lower threshold, Low	0x92	7:0	00000000	RW	PS lower threshold lower byte data
Reserved	0x93	7:3	00000	--	Reserved
PS lower threshold High	0x93	2:0	000	RW	PS lower threshold upper byte data

**Optical Sensor  
LTR-559ALS-01**

**PS\_OFFSET Register (0x94 / 0x95)**

The PS\_OFFSET register defines the offset compensation value for proximity offsets caused by device variations, optical crosstalk and other environment factors. This value will be used and cancelled from the original PS raw data such that the data in PS\_DATA register (0x8D and 0x8E) are the compensated value.

0x94	PS_OFFSET_1 (default = 0x00)							
	B7	B6	B5	B4	B3	B2	B1	B0
	<i>Reserved</i>						<i>PS Offset, High byte</i>	

0x95	PS_OFFSET_0 (default = 0x00)							
	B7	B6	B5	B4	B3	B2	B1	B0
	<i>PS Offset, Low byte</i>							

## Optical Sensor LTR-559ALS-01

### ALS\_THRES Register (0x97 / 0x98 / 0x99 / 0x9A)

The ALS\_THRES\_UP and ALS\_THRES\_LOW registers determines the upper and lower limit of the interrupt threshold value respectively. These two values form a range and the interrupt function compares if the measurement value in ALS\_DATA registers is inside or outside the range. The interrupt function is active if the measurement data is outside the range defined by the upper and lower limits. The data format for ALS\_THRES must be the same as ALS\_DATA registers.

0x97	ALS_THRES_UP_0 (default = 0xFF)							
	B7	B6	B5	B4	B3	B2	B1	B0
	<i>ALS Upper Threshold Low</i>							

0x98	ALS_THRES_UP_1 (default = 0xFF)							
	B7	B6	B5	B4	B3	B2	B1	B0
	<i>ALS Upper Threshold High</i>							

0x99	ALS_THRES_LOW_0 (default = 0x00)							
	B7	B6	B5	B4	B3	B2	B1	B0
	<i>ALS Lower Threshold Low</i>							

0x9A	ALS_THRES_LOW_1 (default = 0x00)							
	B7	B6	B5	B4	B3	B2	B1	B0
	<i>ALS Lower Threshold High</i>							

## Optical Sensor LTR-559ALS-01

Field	Address	Bits	Default	Type	Description
ALS upper threshold Low	0x97	7:0	11111111	RW	ALS upper threshold lower byte data
ALS upper threshold High	0x98	7:0	11111111	RW	ALS upper threshold upper byte data
ALS lower threshold Low	0x99	7:0	00000000	RW	ALS lower threshold lower byte data
ALS lower threshold High	0x9A	7:0	00000000	RW	ALS lower threshold upper byte data

## Optical Sensor LTR-559ALS-01

### INTERRUPT PERSIST Register (0x9E)

The INTERRUPT PERSIST register controls the N number of times the measurement data is outside the range defined by the upper and lower threshold limits before asserting the interrupt.

0x9E	INTERRUPT PERSIST (default = 0x00)							
	B7	B6	B5	B4	B3	B2	B1	B0
	<i>PS Persist</i>				<i>ALS Persist</i>			

Field	Bits	Default	Type	Description	
PS Persist	7:4	0000	RW	0000	Every PS value out of threshold range (default)
				0001	2 consecutive PS values out of threshold range
				....	....
				1111	16 consecutive PS values out of threshold range
ALS Persist	3:0	0000	RW	0000	Every ALS value out of threshold range (default)
				0001	2 consecutive ALS values out of threshold range
				---	---
				1111	16 consecutive ALS values out of threshold range

### 10. Device Operation (using Interrupt)

Below flow diagram illustrates the LTR-559ALS operation involving the use of Thresholds and Interrupts.

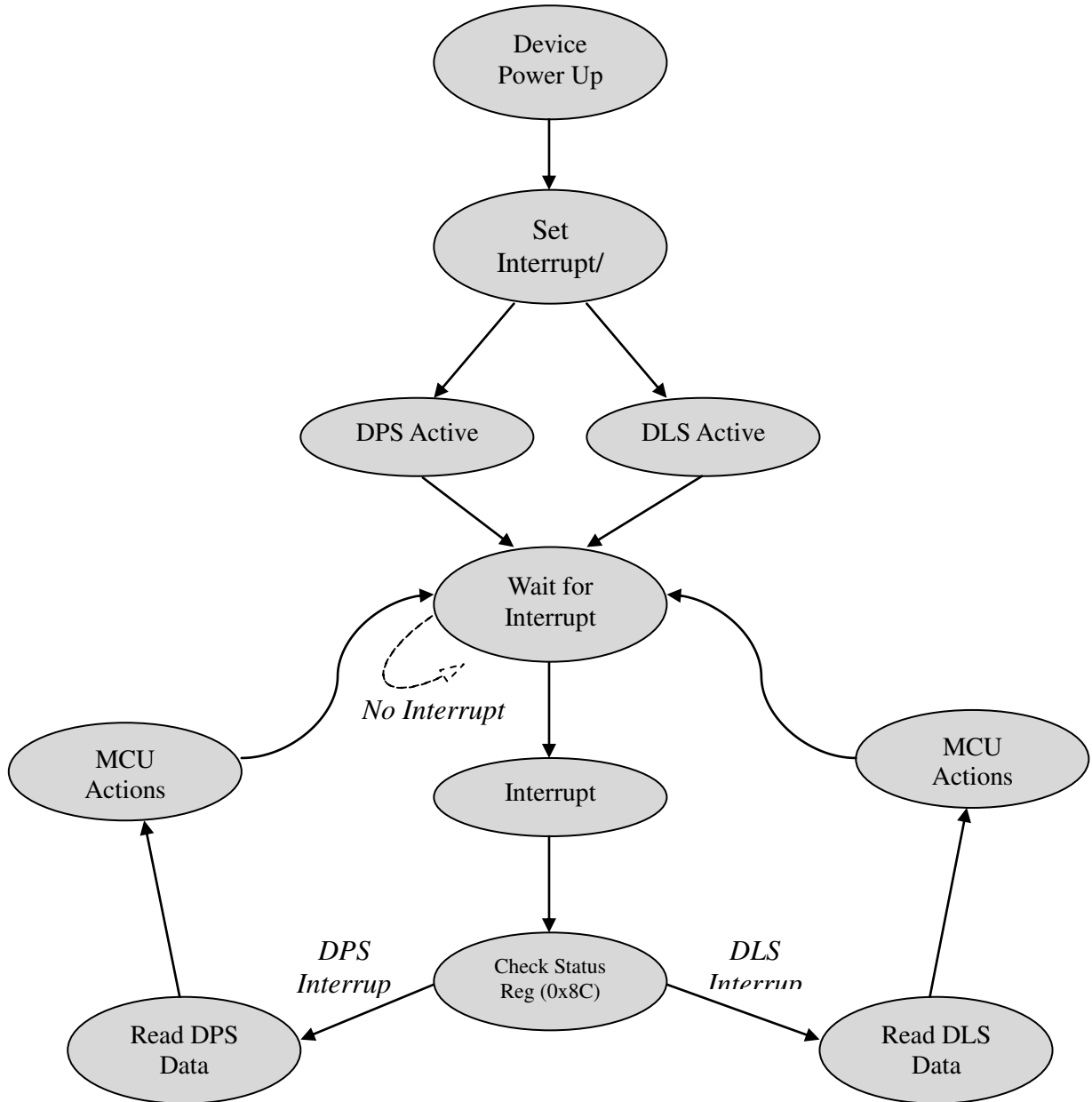

## Optical Sensor LTR-559ALS-01

### 11. Pseudo Codes Examples

#### Control Registers

// The Control Registers define the operating modes and gain settings of the ALS and PS of LTR-559.  
// Default settings are 0x00 for both registers (both in Standby mode).

Slave\_Addr = 0x23 // Slave address of LTR-559 device

#### // Enable ALS

Register\_Addr = 0x80  
Command = 0x01

// ALS\_CONTR register  
// For Gain X1  
// For Gain X2, Command = 0x05  
// For Gain X4, Command = 0x09  
// For Gain X8, Command = 0x0D  
// For Gain X48, Command = 0x19  
// For Gain X96, Command = 0x1D

WriteByte(Slave\_Addr, Register\_Addr, Command)

#### // Enable PS

Register\_Addr = 0x81  
Command = 0x03

// PS\_CONTR register

WriteByte(Slave\_Addr, Register\_Addr, Command)

#### PS LED Registers

// The PS LED Registers define the LED pulse modulation frequency, duty cycle and peak current.  
// Default setting is 0x7F (60kHz, 100%, 100mA).

Slave\_Addr = 0x23 // Slave address of LTR-559 device

#### // Set LED Pulse Freq 30kHz (duty cycle 100%, peak curr 100mA)

Register\_Addr = 0x82  
Command = 0x1F

// PS\_LED register  
// Pulse Freq = 30kHz, (duty cyc 100%, peak curr 100mA)  
// For Pulse Freq = 40kHz, (100%, 100mA), Command = 0x3F  
// For Pulse Freq = 50kHz, (100%, 100mA), Command = 0x5F  
// For Pulse Freq = 60kHz, (100%, 100mA), Command = 0x7F  
// For Pulse Freq = 70kHz, (100%, 100mA), Command = 0x9F  
// For Pulse Freq = 80kHz, (100%, 100mA), Command = 0xBF  
// For Pulse Freq = 90kHz, (100%, 100mA), Command = 0xDF  
// For Pulse Freq = 100kHz, (100%, 100mA), Command = 0xFF

WriteByte(Slave\_Addr, Register\_Addr, Command)

#### // Set LED Duty Cycle 25% (pulse freq 60kHz, peak curr 100mA)

Register\_Addr = 0x82  
Command = 0x67

// PS\_LED register  
// Duty Cycle = 25%, (pulse freq 60kHz, peak curr 100mA)  
// For Duty Cycle = 50%, (60kHz, 100mA), Command = 0x6F  
// For Duty Cycle = 75%, (60kHz, 100mA), Command = 0x77  
// For Duty Cycle = 100%, (60kHz, 100mA), Command = 0x7F

WriteByte(Slave\_Addr, Register\_Addr, Command)

## Optical Sensor LTR-559ALS-01

**// Set LED Peak Current 5mA (pulse freq 60kHz, duty cycle 100%)**

Register\_Addr = 0x82

Command = 0x78

// PS\_LED register

// Peak Current = 5mA, (pulse freq 60kHz, duty cyc 100%)

// For Peak Current = 10mA, (60kHz, 100%), Command = 0x79

// For Peak Current = 20mA, (60kHz, 100%), Command = 0x7A

// For Peak Current = 50mA, (60kHz, 100%), Command = 0x7B

WriteByte(Slave\_Addr, Register\_Addr, Command)

### PS Measurement Rate

// The PS\_MEAS\_RATE register controls the PS measurement rate.

// Default setting of the register is 0x02 (repeat rate 100ms)

Slave\_Addr = 0x23

// Slave address of LTR-559 device

**// Set PS Repeat Rate 50ms**

Register\_Addr = 0x84

Command = 0x00

// PS\_MEAS\_RATE register

// Meas rate = 50ms

// For Meas rate = 500ms, Command = 0x04

WriteByte(Slave\_Addr, Register\_Addr, Command)

### ALS Measurement Rate

// The ALS\_MEAS\_RATE register controls the ALS integration time and measurement rate.

// Default setting of the register is 0x03 (integration time 100ms, repeat rate 500ms)

Slave\_Addr = 0x23

// Slave address of LTR-559 device

**// Set ALS Integration Time 200ms, Repeat Rate 200ms**

Register\_Addr = 0x85

Command = 0x12

// ALS\_MEAS\_RATE register

// Int time = 200ms, Meas rate = 200ms

// For Int time = 400ms, Meas rate = 500ms, Command = 0x1B

WriteByte(Slave\_Addr, Register\_Addr, Command)

### ALS Data Registers (Read Only)

// The ALS Data Registers contain the ADC output data for the respective channel.

// These registers should be read as a group, with the lower address being read first.

Slave\_Addr = 0x23

// Slave address of LTR-559 device

**// Read back ALS\_DATA\_CH1**

Register\_Addr = 0x88

ReadByte(Slave\_Addr, Register\_Addr, Data0)

Register\_Addr = 0x89

ReadByte(Slave\_Addr, Register\_Addr, Data1)

// ALS\_DATA\_CH1 low byte address

// ALS\_DATA\_CH1 high byte address

**// Read back ALS\_DATA\_CH0**

Register\_Addr = 0x8A

ReadByte(Slave\_Addr, Register\_Addr, Data2)

Register\_Addr = 0x8B

ReadByte(Slave\_Addr, Register\_Addr, Data3)

// ALS\_DATA\_CH0 low byte address

// ALS\_DATA\_CH0 high byte address

ALS\_CH1\_ADC\_Data = (Data1 << 8) | Data0

ALS\_CH0\_ADC\_Data = (Data3 << 8) | Data2

// Combining lower and upper bytes to give 16-bit Ch1 data

// Combining lower and upper bytes to give 16-bit Ch0 data

## Optical Sensor LTR-559ALS-01

### ALS / PS Status Register (Read only)

// The ALS\_PS\_STATUS Register contains the information on Interrupt, ALS and PS data availability status.  
// This register is read only.

```
Slave_Addr = 0x23 // Slave address of LTR-559 device

// Read back Register
Register_Addr = 0x8C // ALS_PS_STATUS register address
ReadByte(Slave_Addr, Register_Addr, Data)

Interrupt_Status = Data & 0x0A // Interrupt_Status = 8(decimal) → ALS Interrupt
// Interrupt_Status = 2(decimal) → PS Interrupt
// Interrupt_Status = 10(decimal) → Both Interrupt

NewData_Status = Data & 0x05 // NewData_Status = 4(decimal) → ALS New Data
// NewData_Status = 1(decimal) → PS New Data
// NewData_Status = 5(decimal) → Both New Data

ALS_Data_Valid = Data & 0x80 // ALS_Data_Valid = 0x00 → ALS New Data is valid (usable)
// ALS_Data_Valid = 0x80 → ALS New Data is invalid, discard and
// wait for new ALS data
```

### PS Data Registers (Read only)

// The PS Data Registers contain the ADC output data.  
// These registers should be read as a group, with the lower address being read first.

```
Slave_Addr = 0x23 // Slave address of LTR-559 device

// Read back PS_DATA registers
Register_Addr = 0x8D // PS_DATA low byte address
ReadByte(Slave_Addr, Register_Addr, Data0)
Register_Addr = 0x8E // PS_DATA high byte address
ReadByte(Slave_Addr, Register_Addr, Data1)

PS_ADC_Data = (Data1 << 8) | Data0 // Combining lower and upper bytes to give 16-bit PS data
```

### Interrupt Registers

// The Interrupt register controls the operation of the interrupt pins and function.  
// The default value for this register is 0x08 (Interrupt inactive)  
// Note that when this register is to be set with values other than its default values,  
// it should be set before device is in active mode.

```
Slave_Addr = 0x23 // Slave address of LTR-559 device

// Set Interrupt Polarity for Active Low, both ALS and PS trigger
Register_Addr = 0x8F // Interrupt Register address
Command = 0x03 // Interrupt is Active Low and both ALS and PS can trigger
// For Active High Interrupt, both trigger, Command = 0x07
// For Active High Interrupt, ONLY ALS trigger, Command = 0x06
// For Active High Interrupt, ONLY PS trigger, Command = 0x05

WriteByte(Slave_Addr, Register_Addr, Command)
```

## Optical Sensor LTR-559ALS-01

### ALS Threshold Registers

// The ALS\_THRES\_UP and ALS\_THRES\_LOW registers determines the upper and lower limit of the interrupt threshold value.  
 // Following example illustrates the setting of the ALS threshold window of decimal values of 200 (lower threshold)  
 // and 1000 (upper threshold)

```
Slave_Addr = 0x23 // Slave address of LTR-559 device

// Upper Threshold Setting (decimal 1000)
ALS_Upp_Threshold_Reg_0 = 0x97 // ALS Upper Threshold Low Byte Register address
ALS_Upp_Threshold_Reg_1 = 0x98 // ALS Upper Threshold High Byte Register address
Data1 = 1000 >> 8 // To convert decimal 1000 into two eight bytes register values
Data0 = 1000 & 0xFF
WriteByte(Slave_Addr, ALS_Upp_Threshold_Reg_0, Data0)
WriteByte(Slave_Addr, ALS_Upp_Threshold_Reg_1, Data1)

// Lower Threshold Setting (decimal 200)
ALS_Low_Threshold_Reg_0 = 0x99 // ALS Lower Threshold Low Byte Register address
ALS_Low_Threshold_Reg_1 = 0x9A // ALS Lower Threshold High Byte Register address
Data1 = 200 >> 8 // To convert decimal 200 into two eight bytes register values
Data0 = 200 & 0xFF
WriteByte(Slave_Addr, ALS_Low_Threshold_Reg_0, Data0)
WriteByte(Slave_Addr, ALS_Low_Threshold_Reg_1, Data1)
```

### PS Threshold Registers

// The PS\_THRES\_UP and PS\_THRES\_LOW registers determines the upper and lower limit of the interrupt threshold value.  
 // Following example illustrates the setting of the PS dynamic threshold with hysteresis interruption for  
 // decimal value 1000 (for NEAR detection) and 500 (for FAR detection)

```
Slave_Addr = 0x23 // Slave address of LTR-559 device

//For NEAR detection (decimal 1000)
PS_Upp_Threshold_Reg_0 = 0x90 // PS Upper Threshold Low Byte Register address
PS_Upp_Threshold_Reg_1 = 0x91 // PS Upper Threshold High Byte Register address
Data1 = 1000 >> 8 // To convert decimal 1000 into two eight bytes register values
Data0 = 1000 & 0xFF
WriteByte(Slave_Addr, PS_Upp_Threshold_Reg_0, Data0)
WriteByte(Slave_Addr, PS_Upp_Threshold_Reg_1, Data1)

PS_Low_Threshold_Reg_0 = 0x92 // PS Lower Threshold Low Byte Register address
PS_Low_Threshold_Reg_1 = 0x93 // PS Lower Threshold High Byte Register address
Data1 = 0 >> 8 // To convert decimal 0 into two eight bytes register values
Data0 = 0 & 0xFF
WriteByte(Slave_Addr, PS_Low_Threshold_Reg_0, Data0)
WriteByte(Slave_Addr, PS_Low_Threshold_Reg_1, Data1)

//For FAR detection (decimal 500)
PS_Upp_Threshold_Reg_0 = 0x90 // PS Upper Threshold Low Byte Register address
PS_Upp_Threshold_Reg_1 = 0x91 // PS Upper Threshold High Byte Register address
Data1 = 2047 >> 8 // To convert decimal 2047 into two eight bytes register values
Data0 = 2047 & 0xFF
WriteByte(Slave_Addr, PS_Upp_Threshold_Reg_0, Data0)
WriteByte(Slave_Addr, PS_Upp_Threshold_Reg_1, Data1)

PS_Low_Threshold_Reg_0 = 0x92 // PS Lower Threshold Low Byte Register address
PS_Low_Threshold_Reg_1 = 0x93 // PS Lower Threshold High Byte Register address
Data1 = 500 >> 8 // To convert decimal 500 into two eight bytes register values
Data0 = 500 & 0xFF
WriteByte(Slave_Addr, PS_Low_Threshold_Reg_0, Data0)
WriteByte(Slave_Addr, PS_Low_Threshold_Reg_1, Data1)
```

# Optical Sensor LTR-559ALS-01

## 12. Recommended Leadfree Reflow Profile

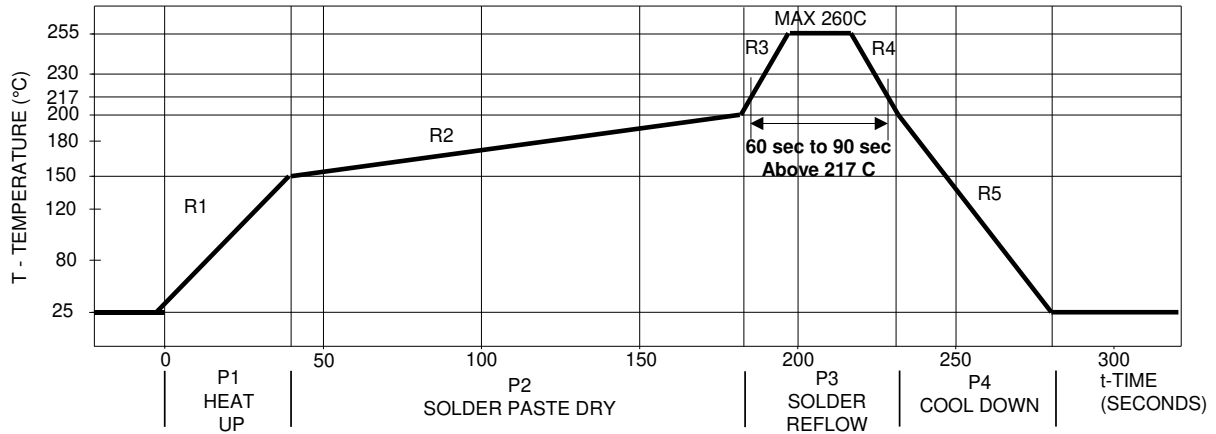

Process Zone	Symbol	$\Delta T$	Maximum $\Delta T/\Delta time$ or Duration
Heat Up	P1, R1	25°C to 150°C	3°C/s
Solder Paste Dry	P2, R2	150°C to 200°C	100s to 180s
Solder Reflow	P3, R3	200°C to 260°C	3°C/s
	P3, R4	260°C to 200°C	-6°C/s
Cool Down	P4, R5	200°C to 25°C	-6°C/s
Time maintained above liquidus point, 217°C		> 217°C	60s to 90s
Peak Temperature		260°C	-
Time within 5°C of actual Peak Temperature		> 255°C	20s
Time 25°C to Peak Temperature		25°C to 260°C	8mins

It is recommended to perform reflow soldering no more than twice.

**Optical Sensor  
LTR-559ALS-01**

**13. Moisture Proof Packaging**

All LTR-559ALS-01 are shipped in moisture proof package. Once opened, moisture absorption begins. This part is compliant to JEDEC J-STD-033A Level 3.

**Time from Unsealing to Soldering**

After removal from the moisture barrier bag, the parts should be stored at the recommended storage conditions and soldered within seven days. When the moisture barrier bag is opened and the parts are exposed to the recommended storage conditions for more than seven days, the parts must be baked before reflow to prevent damage to the parts.

**Recommended Storage Conditions**

<b>Storage Temperature</b>	10°C to 30°C
<b>Relative Humidity</b>	Below 60% RH

**Baking Conditions**

<b>Package</b>	<b>Temperature</b>	<b>Time</b>
In Reels	60°C	48 hours
In Bulk	100°C	4 hours

Baking should only be done once.

**Optical Sensor  
LTR-559ALS-01**

**14. Recommended Land Pattern and Metal Stencil Aperture**

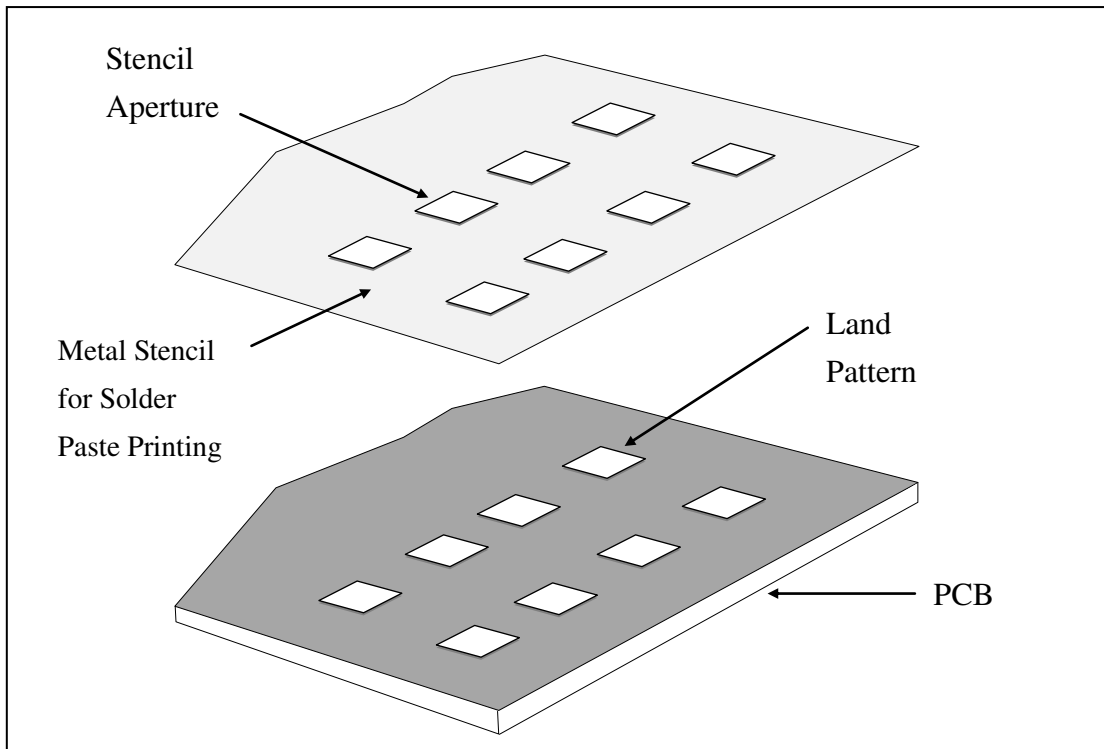

**Recommended Land Pattern**

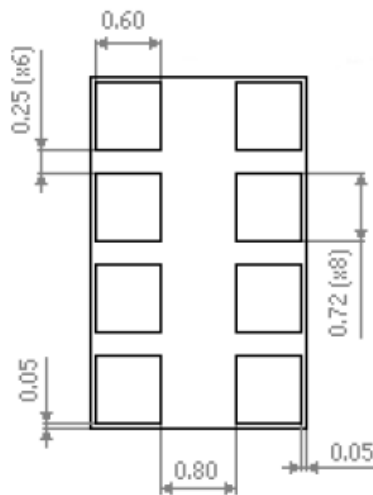

Note: All dimensions are in millimeters

## Optical Sensor LTR-559ALS-01

### Recommended Metal Stencil Aperture

It is recommended that the metal stencil used for solder paste printing has a thickness ( $t$ ) of 0.11mm (0.004 inches / 4 mils) or 0.127mm (0.005 inches / 5 mils).

The stencil aperture opening is recommended to be 0.72mm x 0.60mm which has the same dimension as the land pattern. This is to ensure adequate printed solder paste volume and yet no shorting.

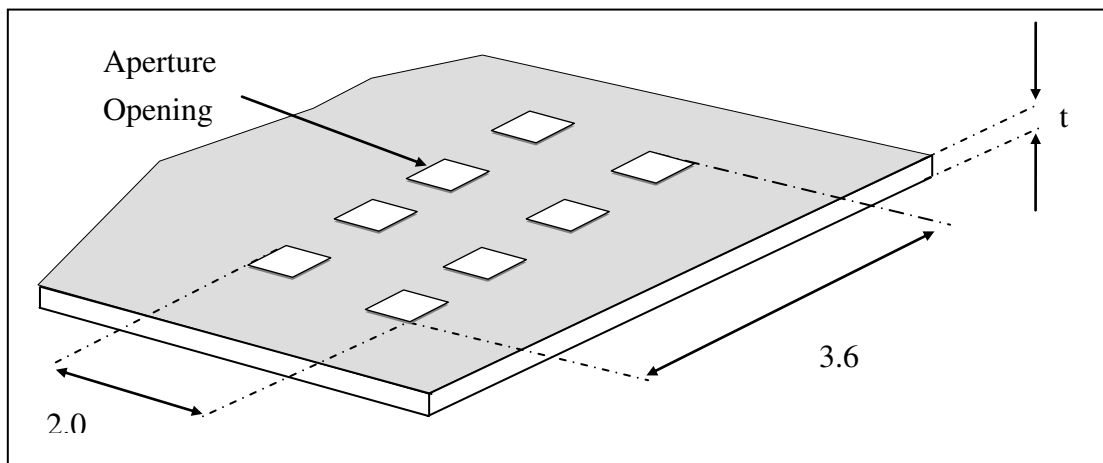

Note:

1. All dimensions are in millimeters

**Optical Sensor  
LTR-559ALS-01**

**15. Package Dimension for Tape and Reel**

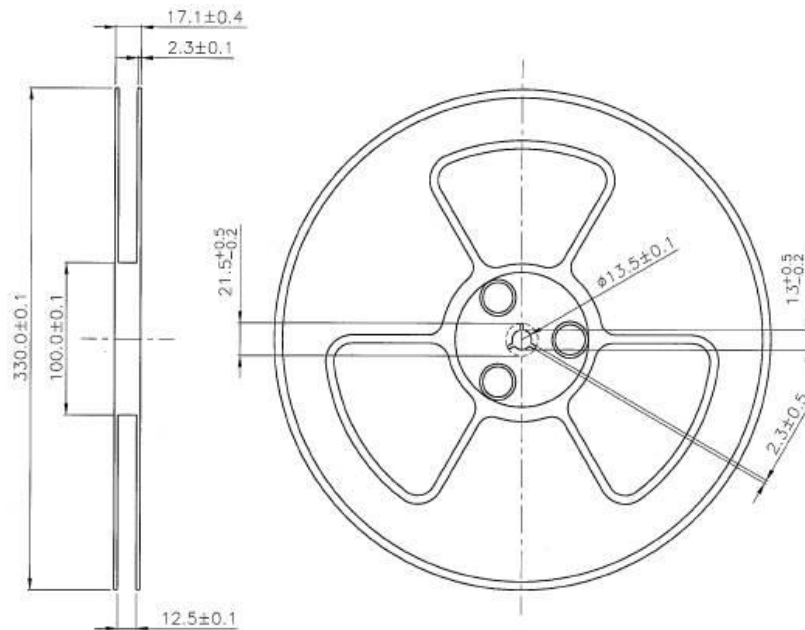
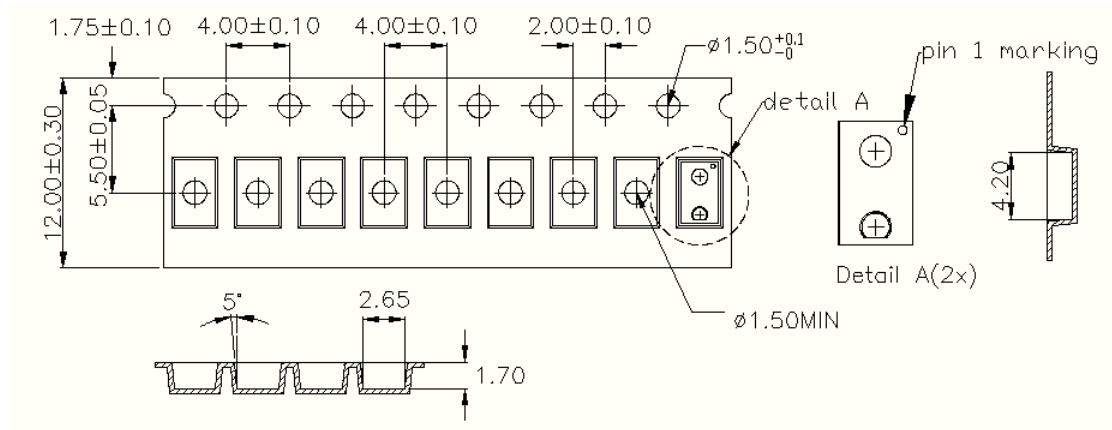

Notes:

1. All dimensions are in millimeters (inches)
2. Empty component pockets sealed with top cover tape
3. 13 inch reel - 8000 pieces per reel
4. In accordance with ANSI/EIA 481-1-A-1994 specifications