

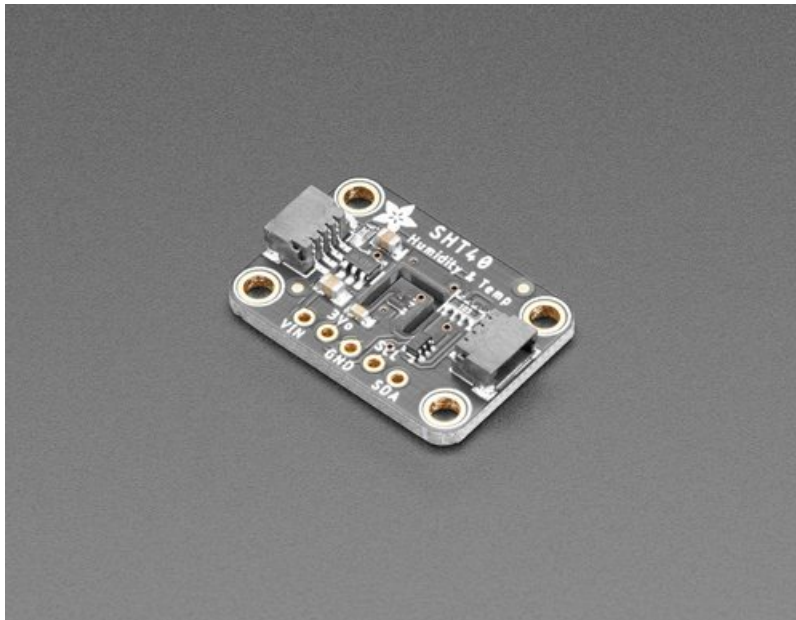

Adafruit Sensirion SHT40 Temperature & Humidity Sensor

Created by Kattni Rembor



Last updated on 2021-02-10 03:25:16 PM EST

Guide Contents

Guide Contents	2
Overview	3
Pinouts	6
Power Pins	6
I2C Logic Pins	6
Arduino	7
Wiring	7
Installation	7
Load Example	8
Example Code	8
Arduino Docs	9
Python & CircuitPython	10
CircuitPython Microcontroller Wiring	10
Python Computer Wiring	10
CircuitPython Installation of SHT4x Library	11
Python Installation of SHT4x Library	11
CircuitPython & Python Usage	12
Full Example Code	12
Python Docs	14
Downloads	15
Files:	15
Schematic	15
Fab Print	15

Overview

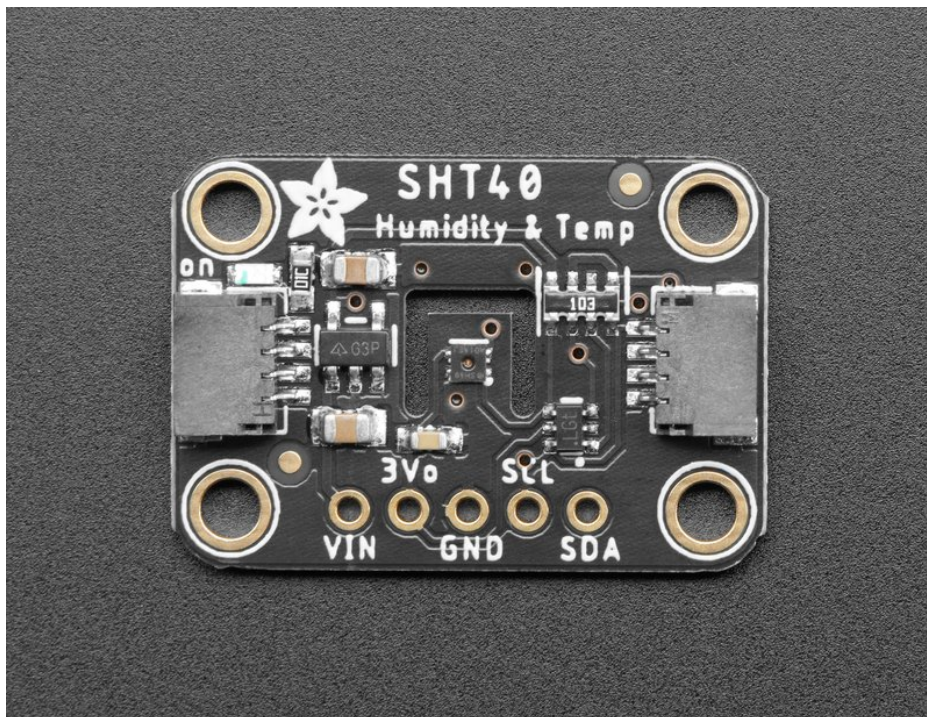

Sensirion Temperature/Humidity sensors are some of the finest & highest-accuracy devices you can get. And finally, we have some that have a true I2C interface for easy reading. The **SHT40** sensor is the fourth generation (started at the SHT10 and worked its way up to the top!). The SHT40 has an excellent $\pm 1.8\%$ typical relative humidity accuracy from 25 to 75% and $\pm 0.2\text{ }^{\circ}\text{C}$ typical accuracy from 0 to 75 $^{\circ}\text{C}$.

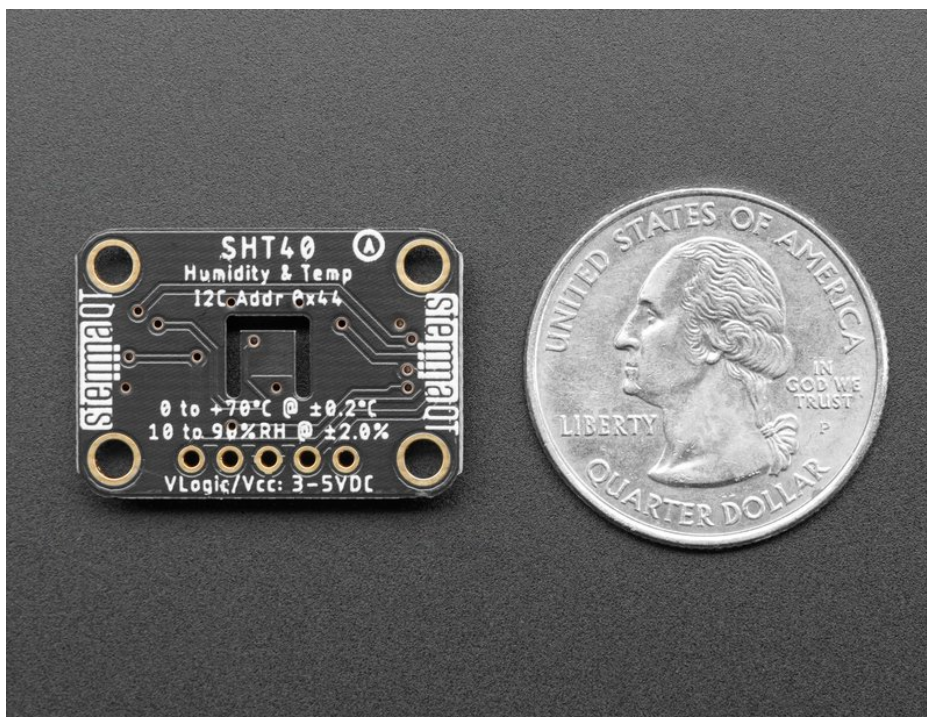

Unlike some earlier SHT sensors, this sensor has a *true* I2C interface for easy interfacing with only two wires (plus power and ground!). Thanks to the voltage regulator and level shifting circuitry we've included

on the breakout It is also is 3V or 5V compliant, so you can power and communicate with it using any microcontroller or microcomputer.

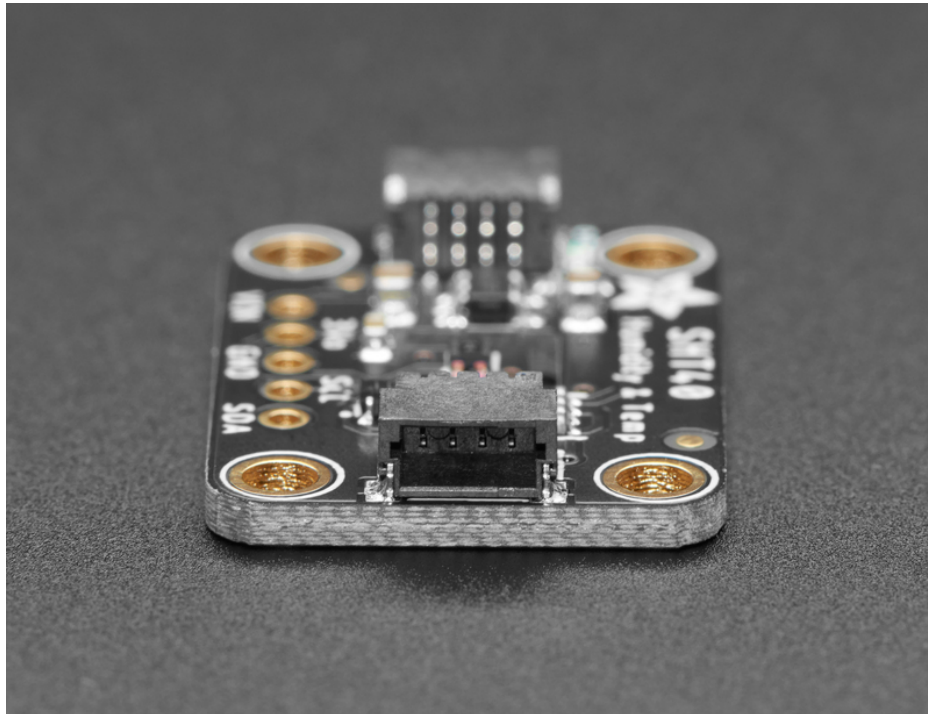

Such a lovely chip - so we spun up a breakout board with the SHT4x and some supporting circuitry such as pullup resistors and capacitors. To make things even easier, we've included [SparkFun Qwiic](https://adafru.it/Fpw) (<https://adafru.it/Fpw>) compatible [STEMMA QT](https://adafru.it/Ft4) (<https://adafru.it/Ft4>) connectors for the I2C bus so you don't even need to solder! [QT Cable](https://adafru.it/JnB) is not included, but we have a variety in the [shop](https://adafru.it/JnB) (<https://adafru.it/JnB>).

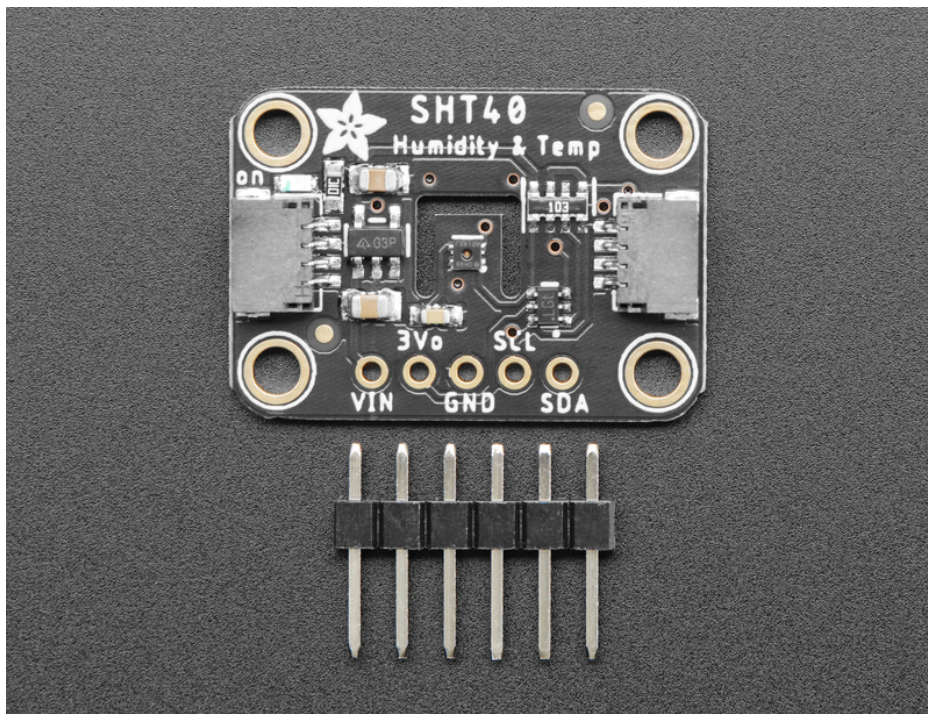

If you prefer working on a breadboard, each order comes with one fully assembled and tested PCB

breakout and a small piece of header. You'll need to solder the header onto the PCB, but it's fairly easy and takes only a few minutes even for a beginner.

We've written both Arduino and CircuitPython/Python library code for this chip, so you can use it with just about any microcontroller or single-board computer like Raspberry Pi.

Pinouts

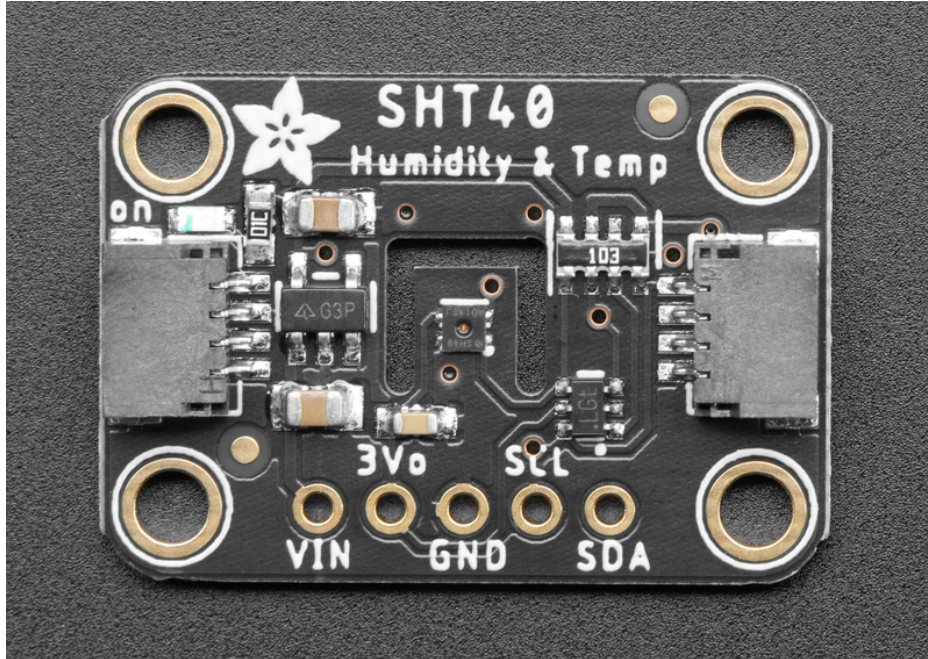

Power Pins

- **VIN** - This is the power pin. To power the board, give it the same power as the logic level of your microcontroller - e.g. for a 5V microcontroller like Arduino, use 5V
- **3V** - This is the 3.3V output from the voltage regulator, you can grab up to 100mA from this if you like.
- **GND** - common ground for power and logic

I2C Logic Pins

- **SCL** - I2C clock pin, connect to your microcontroller I2C clock line. This pin is level shifted so you can use 3-5V logic, and there's a **10K pullup** on this pin.
- **SDA** - I2C data pin, connect to your microcontroller I2C data line. This pin is level shifted so you can use 3-5V logic, and there's a **10K pullup** on this pin.
- **STEMMA QT** (<https://adafruit.com/products/4444>) - These connectors allow you to connect to dev boards with **STEMMA QT** connectors or to other things with [various associated accessories](#) (<https://adafruit.com/products/4444>)

Arduino Wiring

Connecting the SHT40 to your Feather or Arduino is easy:

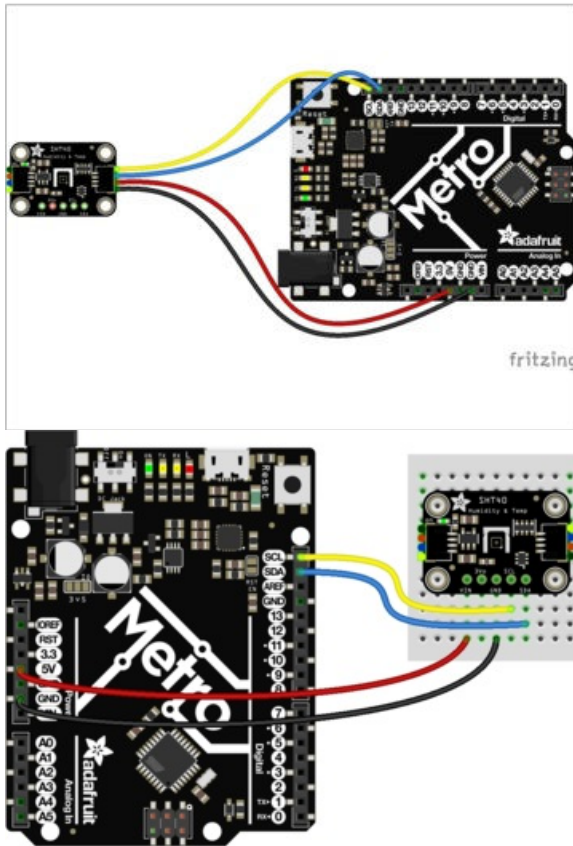

- If you are running a Feather (3.3V), connect **Feather 3V** to board **VIN**
- If you are running a 5V Arduino (Uno, etc.), connect **Arduino 5V** to board **VIN**
- Connect **Feather or Arduino GND** to board **GND**
- Connect **Feather or Arduino SCL** to board **SCL**
- Connect **Feather or Arduino SDA** to board **SDA**

The final results should resemble the illustration above, showing an Adafruit Metro development board.

Installation

You can install the **Adafruit SHT4X Library** for Arduino using the Library Manager in the Arduino IDE:

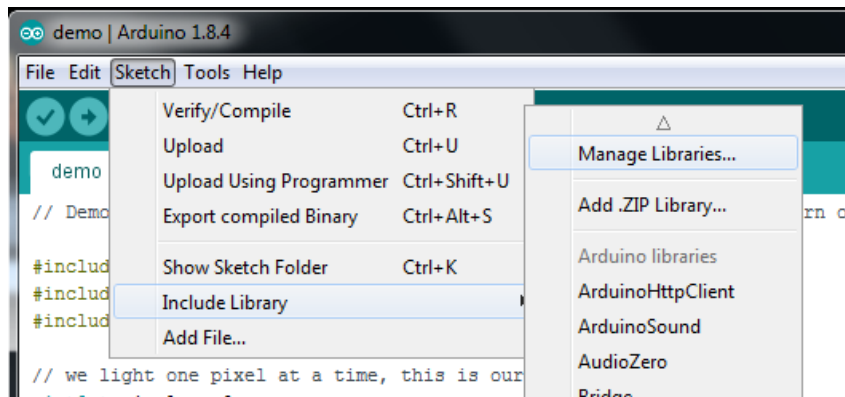

Click the **Manage Libraries ...** menu item, search for **Adafruit SHT4X**, and select the **Adafruit SHT4X** library:

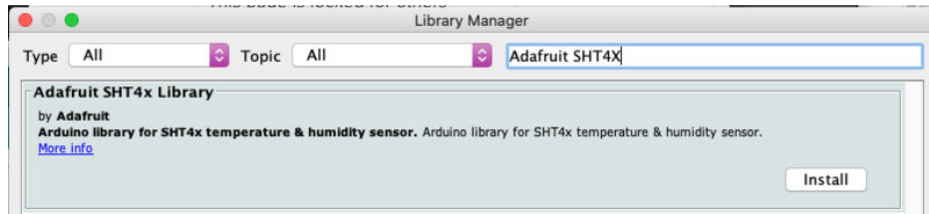

Then follow the same process for the **Adafruit BusIO** library.



Load Example

Open up **File -> Examples -> Adafruit SHT4X -> SHT4test** and upload to your Arduino wired up to the sensor.

Upload the sketch to your board and open up the Serial Monitor (**Tools->Serial Monitor**). You should see the the values for temperature and humidity.

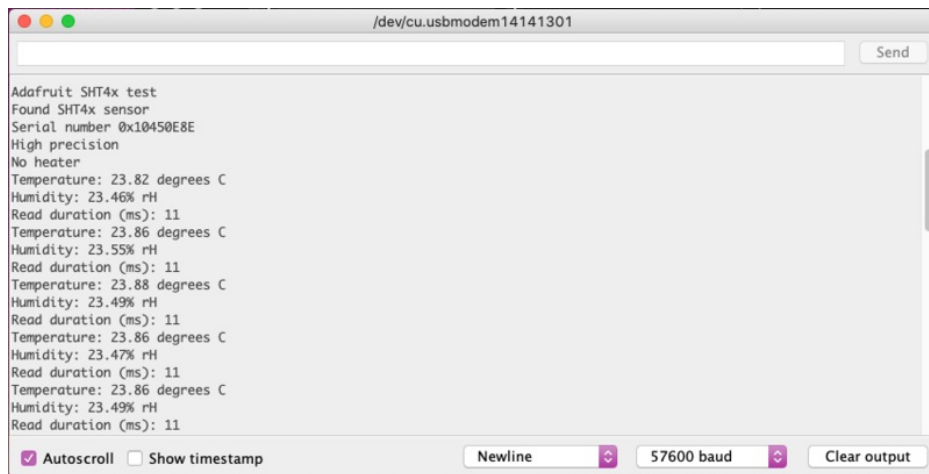

Example Code

The following example code is part of the standard library, but illustrates how you can retrieve sensor data from the SHT40 for the temperature and humidity values:

Temporarily unable to load content:

Arduino Docs

Arduino Docs (<https://adafru.it/Qib>)

□

Python & CircuitPython

It's easy to use the Adafruit SHT40 Temperature & Humidity Sensor with CircuitPython and the [Adafruit CircuitPython SHT4x \(https://adafru.it/Qid\)](https://adafru.it/Qid) module. This module allows you to easily write Python code that reads temperature and humidity data from the sensor.

You can use this sensor with any CircuitPython microcontroller board or with a computer that has GPIO and Python thanks to [Adafruit_Blinka, our CircuitPython-for-Python compatibility library \(https://adafru.it/BSN\)](https://adafru.it/BSN).

CircuitPython Microcontroller Wiring

First wire up an SHT40 to your board exactly as follows. Here is an example of the SHT40 wired to a Feather using I2C:

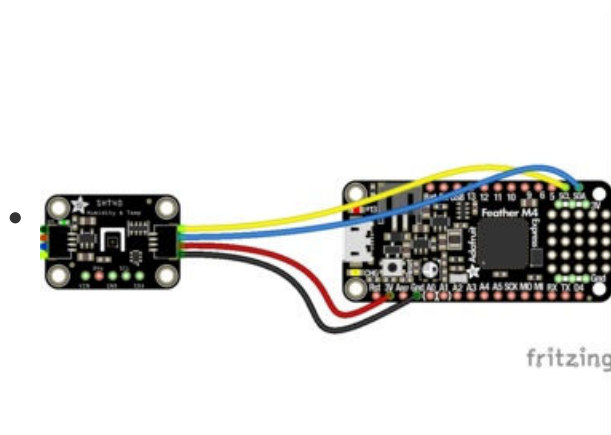

- Board 3V to sensor VIN
- Board GND to sensor GND
- Board SCL to sensor SCL
- Board SDA to sensor SDA

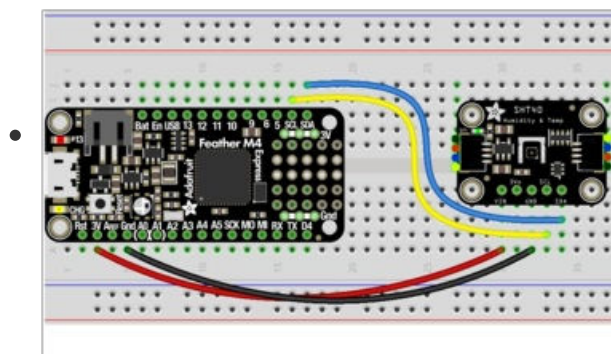

Python Computer Wiring

Since there's *dozens* of Linux computers/boards you can use we will show wiring for Raspberry Pi. For other platforms, [please visit the guide for CircuitPython on Linux to see whether your platform is supported \(https://adafru.it/BSN\)](https://adafru.it/BSN).

Here's the Raspberry Pi wired with I2C:

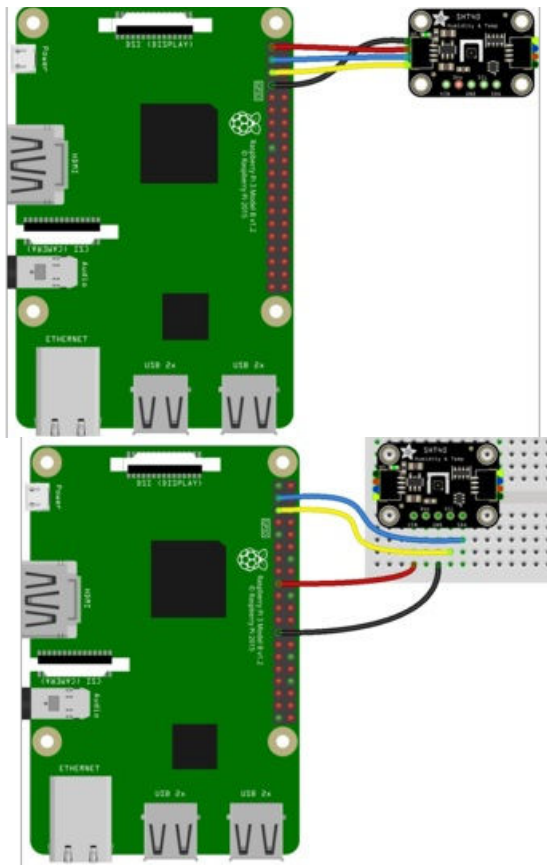

- Pi 3V3 to sensor VIN
- Pi GND to sensor GND
- Pi SCL to sensor SCL
- Pi SDA to sensor SDA

CircuitPython Installation of SHT4x Library

You'll need to install the [Adafruit CircuitPython SHT4x \(https://adafru.it/Qid\)](https://adafru.it/Qid) library on your CircuitPython board.

First make sure you are running the [latest version of Adafruit CircuitPython \(https://adafru.it/Amd\)](https://adafru.it/Amd) for your board.

Next you'll need to install the necessary libraries to use the hardware--carefully follow the steps to find and install these libraries from [Adafruit's CircuitPython library bundle \(https://adafru.it/ENC\)](https://adafru.it/ENC). Our CircuitPython starter guide has a [great page on how to install libraries from the library bundle \(https://adafru.it/ABU\)](https://adafru.it/ABU).

Copy the following file from the bundle to the **lib** folder on your **CIRCUITPY** drive:

- **adafruit_sht4x.mpy**

Before continuing make sure your board's **lib** folder or root filesystem has the **adafruit_sht4x.mpy** file copied over.

Next [connect to the board's serial REPL \(https://adafru.it/Awz\)](https://adafru.it/Awz) so you are at the CircuitPython `>>>` prompt

Python Installation of SHT4x Library

You'll need to install the **Adafruit_Blinka** library that provides the CircuitPython support in Python. This may also require enabling I2C on your platform and verifying you are running Python 3. [Since each platform is a little different, and Linux changes often, please visit the CircuitPython on Linux guide to get your computer ready \(https://adafru.it/BSN\)](#)!

Once that's done, from your command line run the following command:

- `pip3 install adafruit-circuitpython-sht4x`

If your default Python is version 3 you may need to run 'pip' instead. Just make sure you aren't trying to use CircuitPython on Python 2.x, it isn't supported!

CircuitPython & Python Usage

To demonstrate the usage of the sensor we'll initialize it and read from the sensor in the board's Python REPL.

Run the following code to import the necessary modules and initialize the I2C connection with the sensor:

```
import board
import adafruit_sht4x

sht = adafruit_sht4x.SHT4x(board.I2C())
```

Now you're ready to read values from the sensor using these properties:

- **relative_humidity** - The current relative humidity in % rH
- **temperature** - The current temperature in degrees celsius

```
print(sht.temperature)
print(sht.relative_humidity)
```

```
>>> print(sht.temperature)
23.8758
>>> print(sht.relative_humidity)
25.384
```

That's all there is to reading temperature and humidity from the SHT40 sensor!

Full Example Code

```
# SPDX-FileCopyrightText: Copyright (c) 2020 ladyada for Adafruit Industries
#
# SPDX-License-Identifier: MIT

import time
import busio
import board
import adafruit_sht4x

i2c = busio.I2C(board.SCL, board.SDA)
sht = adafruit_sht4x.SHT4x(i2c)
print("Found SHT4x with serial number", hex(sht.serial_number))

sht.mode = adafruit_sht4x.Mode.NOHEAT_HIGHPRECISION
# Can also set the mode to enable heater
# sht.mode = adafruit_sht4x.Mode.LOWHEAT_100MS
print("Current mode is: ", adafruit_sht4x.Mode.string[sht.mode])

while True:
    temperature, relative_humidity = sht.measurements
    print("Temperature: %0.1f C" % temperature)
    print("Humidity: %0.1f %" % relative_humidity)
    print("")
    time.sleep(1)
```

Python Docs

[Python Docs \(https://adafru.it/Qic\)](https://adafru.it/Qic)

Downloads

Files:

- [SHT40 Datasheet \(https://adafru.it/QhD\)](https://adafru.it/QhD)
- [Fritzing object in the Adafruit Fritzing Library \(https://adafru.it/QhE\)](https://adafru.it/QhE)
- [EagleCAD PCB files on GitHub \(https://adafru.it/QhF\)](https://adafru.it/QhF)

Schematic

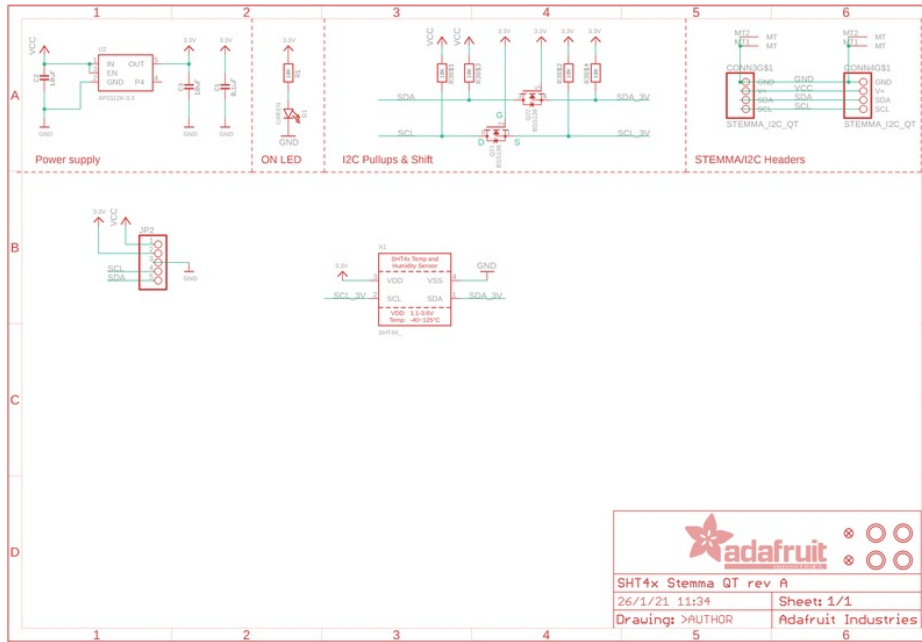

Fab Print

